

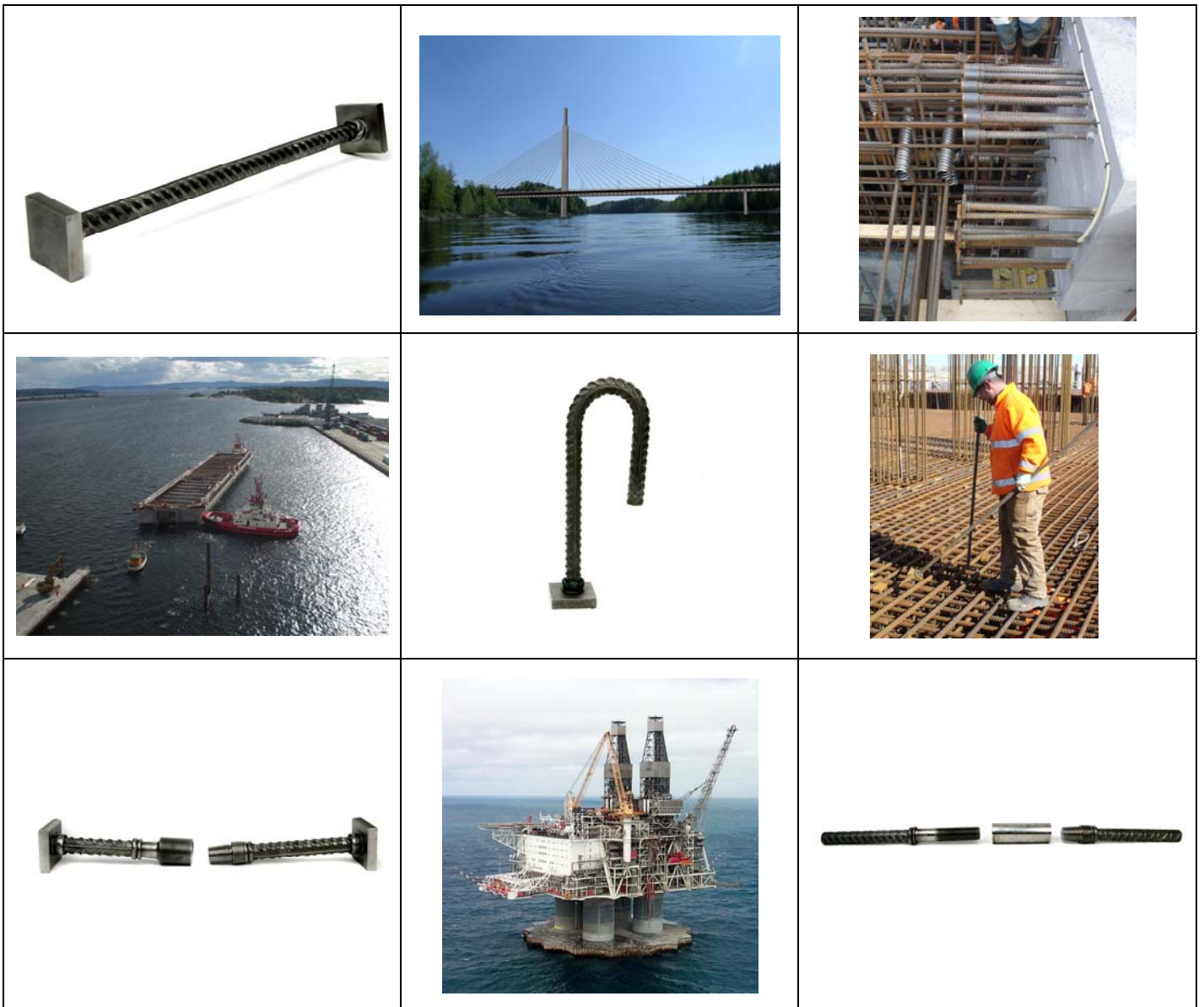

HIGH PERFORMANCE REINFORCEMENT PRODUCTS

Product Catalogue



HRC and its product philosophy

The use of T-headed bars in concrete structures has some remarkable benefits compared to the use of conventional reinforcement. These benefits are of great importance for the contractor as well as the designer.

Headed Reinforcement Corp. (HRC), located in USA (California) and Norway, is a manufacturer of reinforcement products, such as T-headed bars, mechanical couplers and anchor/foundation bolts. We deliver products for installation in concrete structures all over the world.

All HRC-products are designed to exceed the actual stress and strain capacity of any reinforcement grade, independent of variable heats. The high quality standard is one of the main reasons for our position as one of the world leading companies in rebar-anchoring and splicing technology.

Contents

About HRC and its product-philosophy	1
T-headed bars – characteristics and advantages	3
Products	
HRC 100 series – T-headed bars	5
HRC 200 series – T-heads for fatigue load	7
HRC 400 series – reinforcement couplers with tapered threads	9
HRC 700 series – foundation bolts	11
Application	
Fastening of guardrails on bridges	13
Shear reinforcement with T-headed bars	14
T-headed bars in Eurocodes	17
T-headed bars and Strut-and-tie-modelling	18
Examples	19
Properties of reinforcement bars	23

T-headed bars – characteristics and advantages

Characteristics

HRC T-headed bars are common reinforcing bars with a head attached to one or both ends.

The head is fixed to the rebar by friction welding. The friction weld secures a firm and reliable connection between head and bar. Anchorage by HRC T-heads has some special characteristics compared to other types of reinforcement:

- Concentrated transfer of the full tensile capacity of the rebar without the need of bond between reinforcing steel and the surrounding concrete.
- Very stiff connection between steel and concrete, that means nearly no slip compared to common reinforcement with a bend or hook.
- Better fatigue performance than bent reinforcing bars (HRC 200 series).



Advantages

The special characteristics give some advantages both in design and for the practical use on site:

- Concentrated load transfer eliminates the need for anchoring length. Thus the full length of the bar can be utilized. This leads to reduced congestion of reinforcement and can reduce concrete dimensions (e.g. beams with direct support). Additionally the use of larger bar diameters becomes possible where appropriate.
- Concentrated load transfer makes it possible to use larger bar diameters for shear reinforcement because there is no need for anchorage with hooks. Thus the number of shear reinforcement bars can be reduced in congested areas (for instance one $\text{Ø}25$ equals 4,3 $\text{Ø}12$), reducing installing time drastically and improving casting conditions.
- Concentrated load transfer, without the use of bond, secures the anchorage of the reinforcement even in the case of loss of the concrete cover. This means improved robustness in accidental situations and thus more safety.

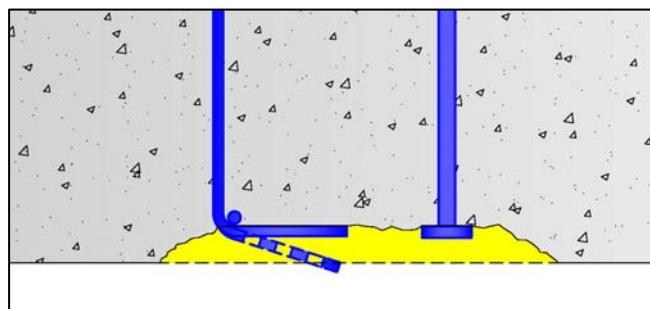

- Concentrated load transfer, without the use of bond, makes it possible to use plain high-strength steel as reinforcement. This is of special interest in constructions where it is desirable to distribute tension strain over the full length of the rebar to increase the ductility of the construction.
- Stiff anchorage of shear reinforcement reduces shear strain, decreasing the width of the shear cracks. This will increase the friction in the crack (aggregate interlock), giving a higher shear capacity of the concrete. (The Canadian Code "Design of Concrete Structures" takes already account of this.)
- Stiff anchorage of transversal reinforcement reduces transversal strain under compression load, generating compression stresses in transversal direction (confinement effect). This increases the capacity of the construction under compression loads and increases the ductility of the construction. The latter is especially important under accidental or earthquake loads.
- Improved fatigue performance reduces the reinforcement requirements in constructions prone to fatigue loads.

The advantages mentioned above are leading to new opportunities and a more flexible design and at the same time improve casting conditions, effectiveness and reduce building costs. Improved casting conditions can in most cases give higher durability, higher safety and reduced costs of maintenance.



The characteristics and advantages have been studied and documented during excessive research in Norway, Canada and the USA. Most design standards support the use of end anchoring devices.

HRC offers a reliable and economical method of fixing the head to the rebar.

HRC 100 series – T-headed bars

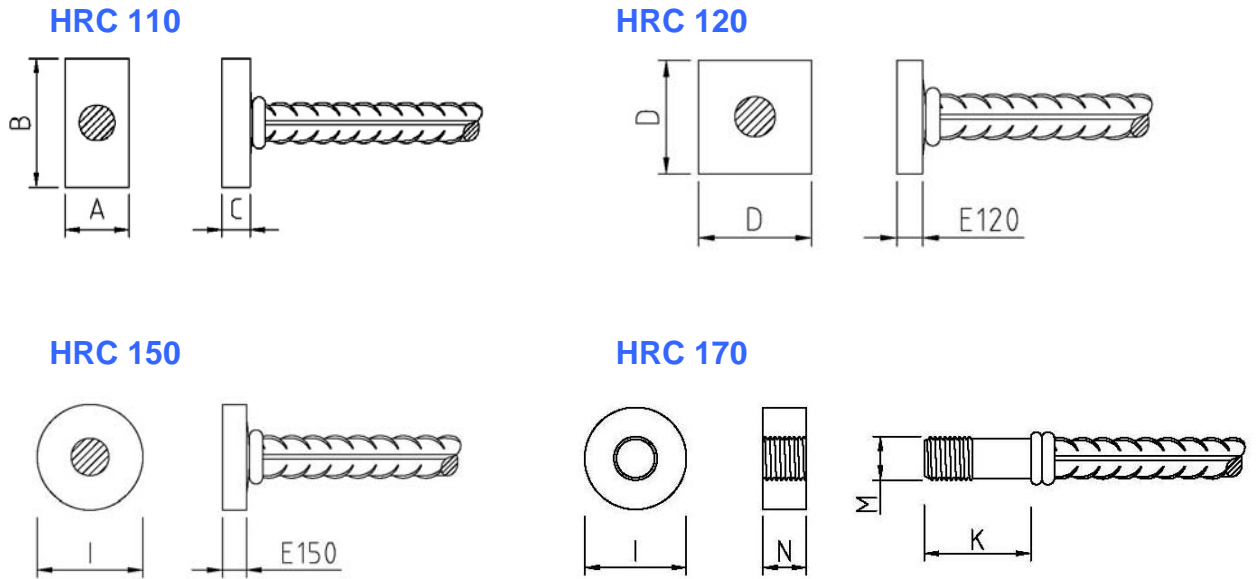

Nominal diameter of reinforcement bar	Head Dimensions										
	∅	A	B	C	D	E120	E150	I	K	M	N
mm	mm	mm	mm	mm	mm	mm	mm	mm	mm	mm	mm
16	35	60	16	50	12	12	50	70	M18	20	
20	40	80	18	60	14	16	65	70	M24	25	
25	50	100	20	70	16	20	80	75	M30	30	
28, 32	65	120	25	90	20	25	100	100	M38	40	
40	-	-	-	110	25	-	-	-	-	-	

HRC 110/120/150 are covered by an European Technical Approval (ETA – 08/0035) and bear the CE-marking

- Head dimensions are based on concrete compressive strength of 30MPa. Higher concrete strength results in more conservative design.
- All products are designed to exceed the actual stress and strain capacity of the rebar
- Mechanical properties that fulfill the ductility requirements for reinforcement steel with a characteristic yield strength of 500 MPa in accordance to EN 10080.
- Can be combined with 180° hook or other HRC products

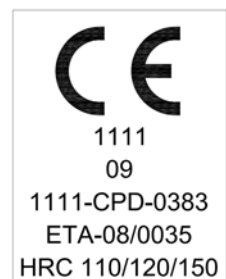
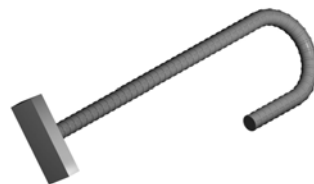
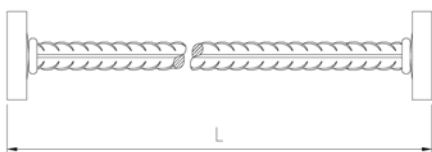

Series 100 are available in length 200- 12 000mm (up to 18 000mm as special order)

T-headed Bars HRC 100 series – performance

Reduced Congestion with T-Headed Bars:

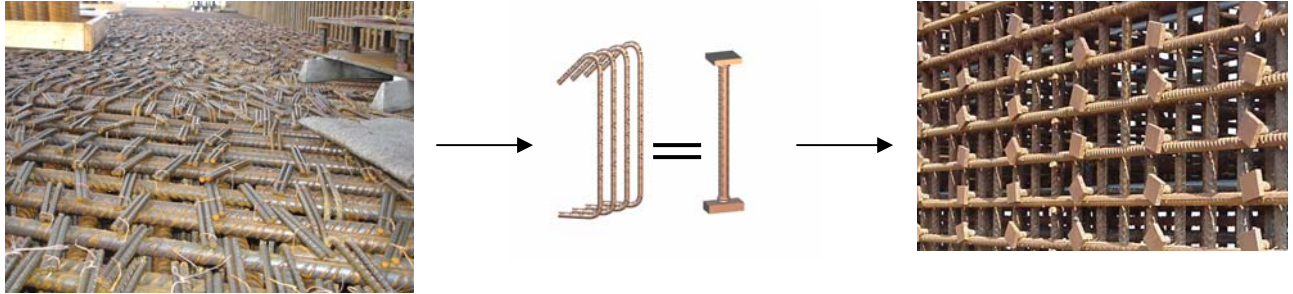

Avoid installation errors and problems with field tolerances:



A typical situation in the field
- not according to building standards.

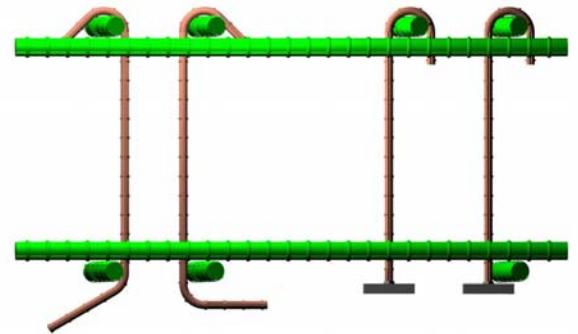

Strirups:
Field tolerances
reduce anchoring

T-Headed Bars:
Full anchorage and
good support to
bottom bar.

Improved robustness at overload and accidental conditions:

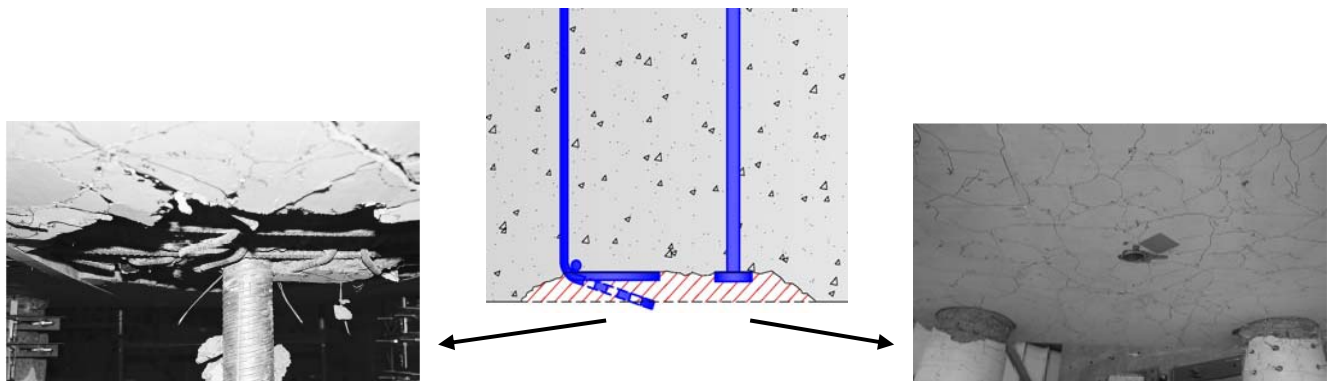

HRC 200 series – T-headed bars for fatigue load

HRC 200 series was developed especially for fatigue performance. It has a special geometry with forged T-heads and the head-to-bar connection in a distance from the head.

The HRC 200 series combines all advantages of the HRC 100 with improved resistance under fatigue loads (as wave- or traffic loads).

HRC 210

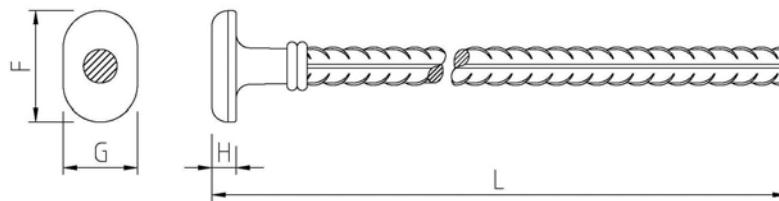

HRC 220

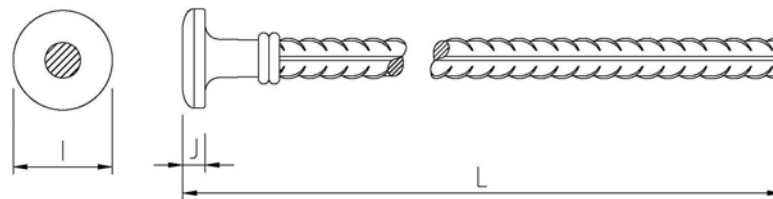

Nominal diameter of reinforcement bar	Head Dimensions				
	F	G	H	I	J
Ø	mm	mm	mm	mm	mm
16	60	30	12	50	12
20	72	40	14	60	14
25	90	45	18	70	16
28, 32	115	64	22	90	20
36, 40	special order				

- All products are designed to exceed the actual stress and strain capacity of the rebar
- Mechanical properties that fulfill the ductility requirements for reinforcement steel with a characteristic yield strength of 500 MPa in accordance to EN 10080.
- Can be combined with 180° hook or other HRC products

Series 200 are available in length 200- 12 000mm (up to 18 000mm as special order)

T-headed Bars HRC 200 series – performance

The curves underneath show the fatigue performance of HRC 200 series T-headed reinforcement compared to the design curves for straight and bended bars according to EN 1992-1-1:2004. The design curve for HRC T-heads are the result of a research project undertaken by SINTEF in Norway (report STF 65 F86088; “Fatigue life of forged and plate headed anchoring bars”).

The diagram shows that the fatigue performance of HRC 200 series is comparable with that of straight reinforcement bars and better than the fatigue performance for bended bars. With other words: substituting bends with HRC 200 T-heads will increase the fatigue performance significantly.

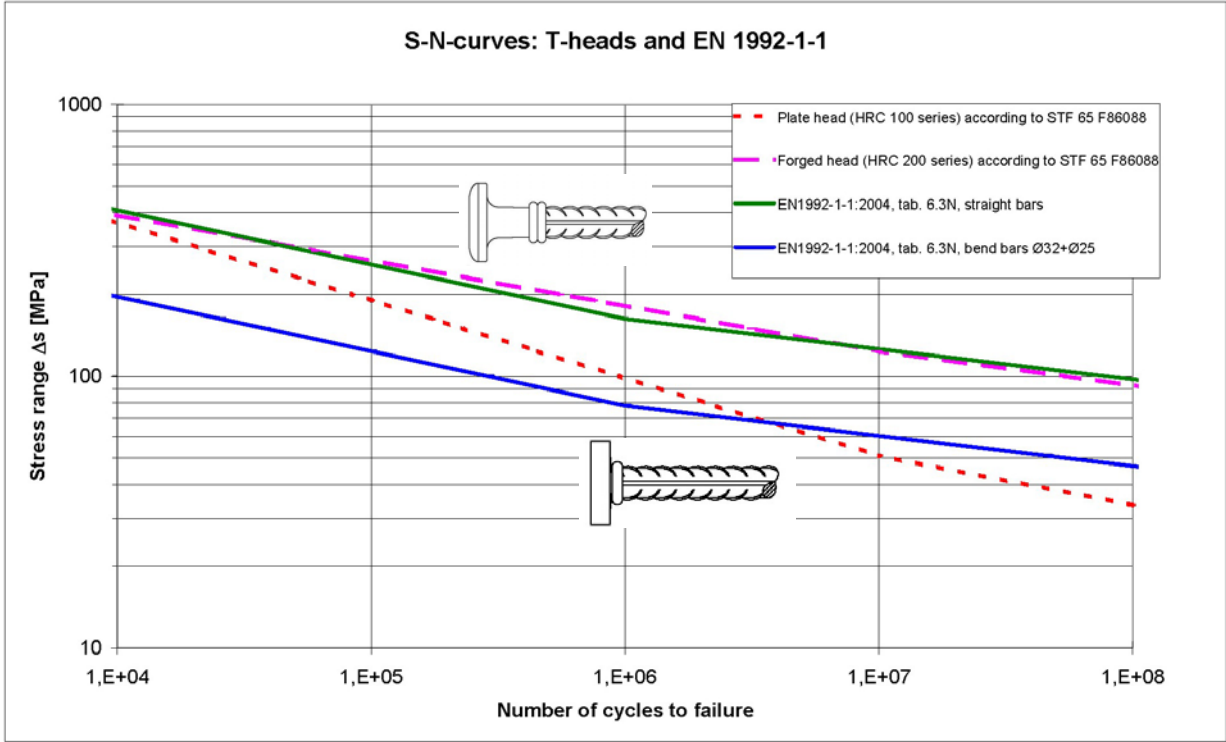

HRC 400 series – couplers with tapered threads

Standard Couplers

Position Couplers with length adjustment

HRC 410 (Male)

HRC 420 (Female)

HRC 410 (Male)

HRC490 (Sleeve)

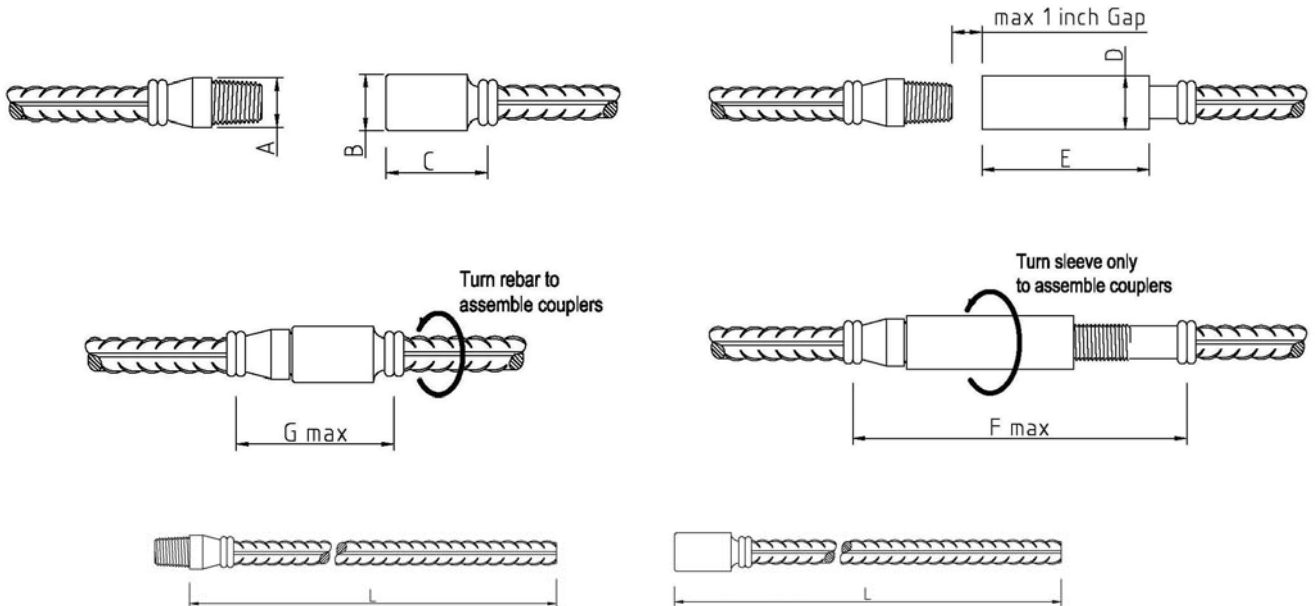

Series 400 are available in length 200- 12 000mm (up to 18 000mm as special order)

Nominal diameter of reinforcement bar	Sleeve and Thread Dimensions							
Ø	A	B	C	D	E	F max	G max	Torque
mm	mm	mm	mm	mm	mm	mm	mm	Nm
12	22	22	45	-	-	-	72	160
16	28	28	50	-	-	-	76	200
20	35	35	55	-	-	-	85	200
25	35	42	76	-	-	-	113	270
32	45	55	90	55	157	330	135	270
40	special order							

- All products are designed to transfer the full actual tensile capacity of the rebar. Thus both stress and strain capacity of the spliced rebar can be used.
- Fulfills and exceeds all requirements of ISO 15835 “Reinforcement couplers for mechanical splices of bars” (including fatigue and earthquake classes)
- Transition to different reinforcing bar sizes is available.
- Mechanical properties that fulfill the ductility requirements for reinforcement steel with a characteristic yield strength of 500 MPa in accordance to EN 10080.
- Can be combined with other HRC products.
- Can be delivered with nail-on flange.
- Can be produced in **stainless steel** as special order, also with stainless rebar.

DON'T MAKE THE SPLICE YOUR WEAK LINK!



HRC 420



HRC 410

HRC 120

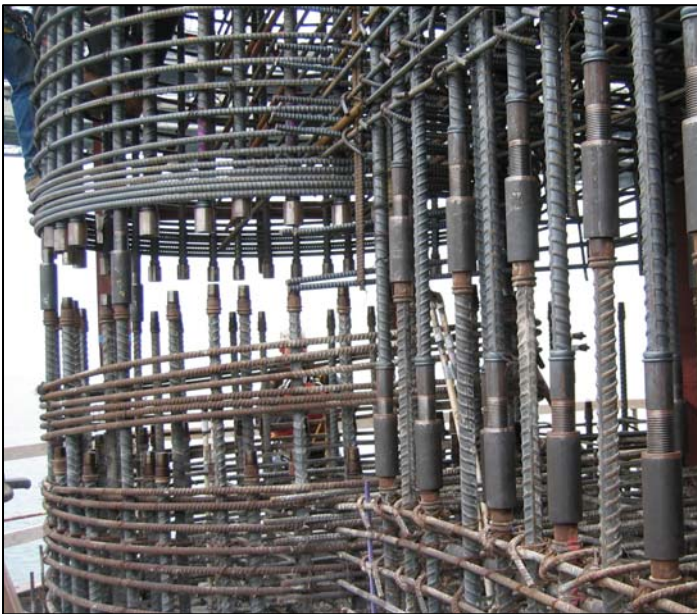

HRC 490 Position coupler used to connect pre-tied reinforcement.

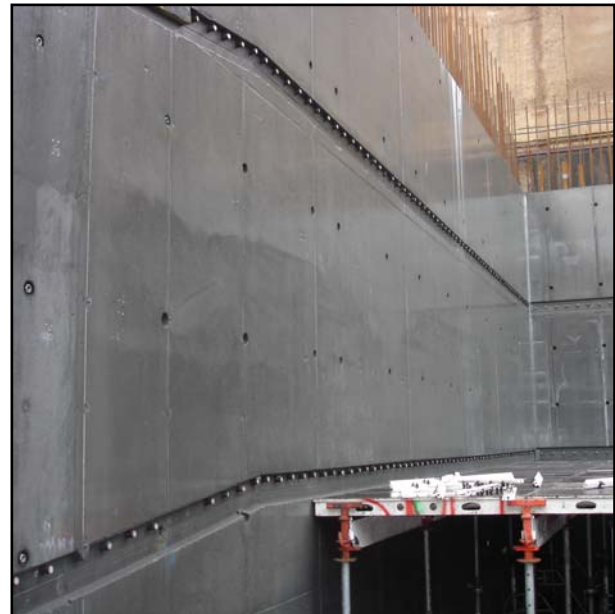

Use of HRC 410/420 coupler system for slab/wall connection.

HRC 400 Series - Technically Speaking:

- Exceeds all international known requirements for rebar couplers, including reinforcement design specifications for seismic events
- Designed to exceed the actual stress and strain capacity of all reinforcement grades, independent of variable heats
- Behaves like continuous reinforcement and provides full utilization of the strength and ductility properties of the reinforcement
- It will simply put your tensile test failure outside the splicing area and break in the bar

HRC 400 Series - Practically Speaking:

- Taper Threads provide a fast, simple and self-locking installation
- Reliable Quality Control provided by visual inspection and a torque wrench
- HRC 490 Position Coupler - Splice long and high dimension reinforcement without turning the bars
- Less sensitive for tolerances and rough field conditions than any other mechanical coupler
- Excellent for use in casting joints

HRC 700 series – foundation bolts

HRC 700 Series products come not in certain fixed lengths, but are tailor made to fit projects needs. Thus they can be an integrated part of the reinforcement.

HRC 710

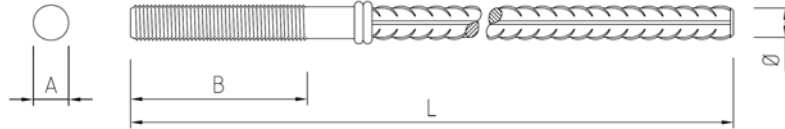

Thread diameter	Nominal diameter of reinforcing bar	Thread length HRC 710			T-head ¹	Characteristic yield-load	Characteristic tensile-load
A	Ø	B			H ¹	kN	kN
	mm	mm	mm	mm	mm		
M18	16	-	125	200	50	100	115
M20	20	-	125	200	60	110	134
M24	20	-	150	200	60	157	180
M27	25	100	150	250	70	206	252
M30	25	-	150	250	70	245	282
M36	32	-	170	300	90	402	462

¹when combined with HRC 120 Series T-head

HRC 720 / HRC 720SS

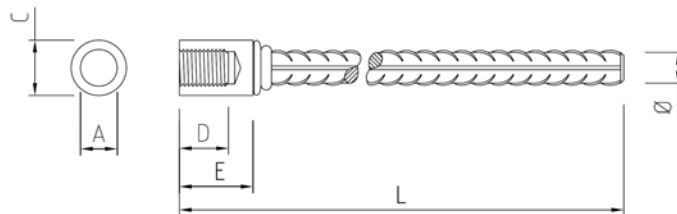

Thread diameter	Nominal diameter of reinforcing bar	HRC 720			HRC 720SS ² (stainless steel sleeve, "black" rebar)			T-head ¹
A	Ø	C	D	E	C	D	E	H ¹
	mm	mm	mm	mm	mm	mm	mm	mm
M18	20	28	30	50	30	30	60	60
M20	25	35	35	55	38	35	60	70
M24	25	35	40	60	45	40	60	70
M30	32	45	50	70	50	50	70	90
M36	40	55	60	80	-	-	-	110

¹when combined with HRC 120 Series T-head

²special order with possible longer delivery time

Series 700 are available in length 250 - 12 000mm (up to 18 000mm as special order)

Bearing capacity of HRC 700 Series:

For HRC 710 the bearing capacity is given in the table as characteristic yield- and tensile load.
For HRC 720/ HRC 720SS the capacity is at least like a threaded rod of quality 8.8.

Possible combinations:

Products of HRC 700 Series can be combined with other HRC-products (T-heads or rebar couplers) and can be delivered with threaded rods, nuts and washers.

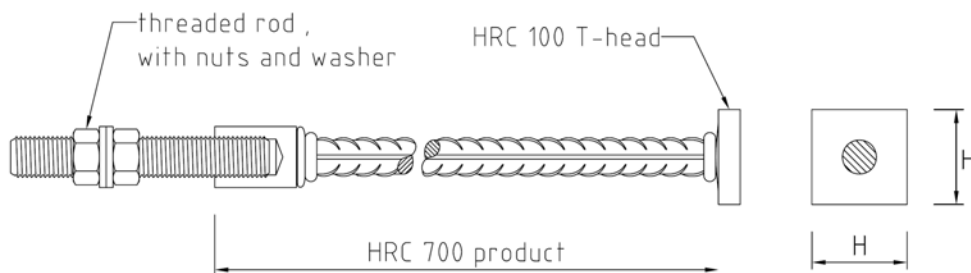

Example of use of HRC 720 Series:

- (1) Foundation coupler is installed even with the surface of the foundation and cast in. The opening in the sleeve is closed with a plastic cap to prevent cement lime or dirt from entering into the sleeve. There are no protruding part witch can be damaged or could present a danger.
- (2) The treaded part is screwed into the sleeve. Under combined tension- and shear load the high-strength material of the bolt will guarantee the necessary capacity. Maximum allowable tension load is limited by the capacity of the bolt (up to strength 8.8), but shear load is restricted by the concrete pressure against the sleeve.
- (3) The outer diameter of the sleeve gives the bolt better transversal contact against the concrete and therefore a higher shear capacity compared to cast in threaded rods. Higher capacity in the threaded part can therefore be used to transmit big shear forces from a footing and down into the concrete.
- (4) Screwed in threaded parts make it possible to change damaged parts in an easy way and at the same time to keep a sound foundation.

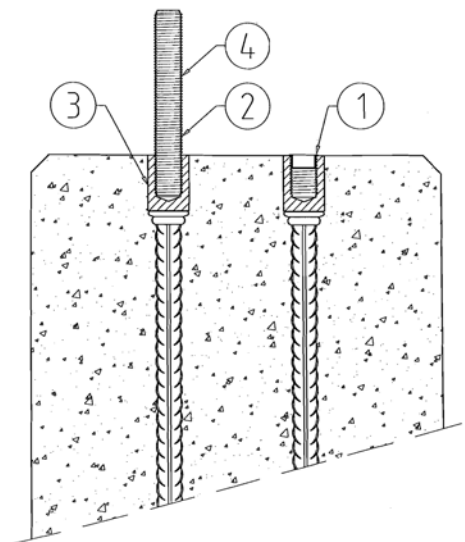

Application: fastening of guardrails on bridges

The Norwegian road administration "Statens Vegvesen" proposes a new solution for fastening of poles for guardrails on bridges, poles for traffic signs, lighting masts etc. using HRC-products. This new solution will ease the construction (saving cost and time) and later the maintenance of the bridge.

The fastening system uses HRC 300 metric couplers of stainless steel attached to a T-headed rebar $\varnothing 20\text{mm}$. The pole is mounted by M20 bolts leaving a gap of approximately 50mm to the concrete surface.

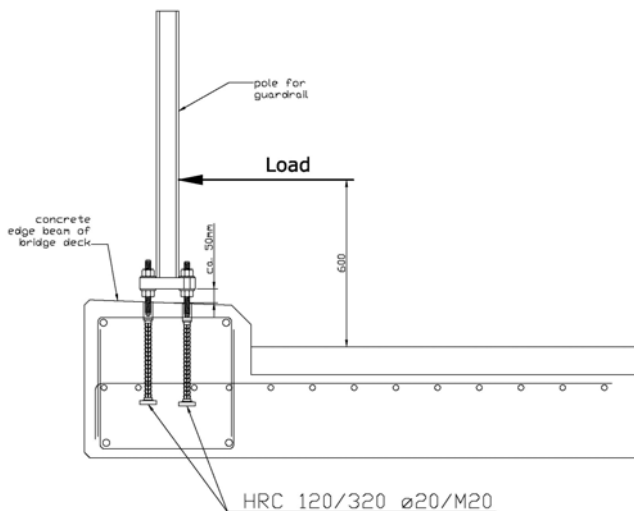
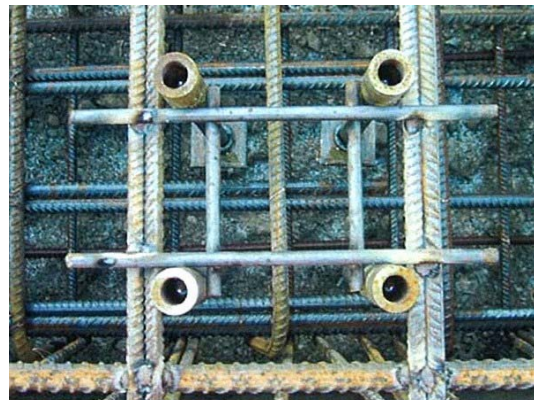

The use of the HRC 300 components has several advantages:

- in the construction phase there are no protruding bolts which can be damaged (the sleeves are protected by plastic plugs from dirt or concrete entering into it)
- it is possible to change the bolts if necessary without any concrete work
- connection between stainless steel (sleeve) and black steel (rebar) possible
- in an accident situation the pole will perform satisfactory as most of the deformation takes place in the pole, not in the fastening bolts

Shear reinforcement with T-headed bars

T-headed bars are suitable as shear reinforcement in many kinds of constructions.

HRC T-headed bars anchor the full capacity of the rebar in the head only. That means no hook or bend is necessary for full anchoring of the bar. This makes it possible to avoid congestion with many thin bars by fewer using bars with large diameter were appropriate. The installation will speed up and casting conditions are improved securing a good quality of the finished construction.

HRC T-heads provide full anchoring even when the concrete cover gets lost (f. instance by accident).

Compared to traditional shear reinforcement, HRC T-headed bars are easier and much faster to install. This saves construction time, avoids errors in placing and makes the result easy to control.

T-heads provide a stiffer anchoring of the rebar compared to bends, resulting in smaller crack widths for shear cracks. Thus an increased aggregate interlock will increase the concrete contribution to shear strength.

Under in plane compression the T-heads add confinement by head bearing directly against the concrete core. This is very important for shear walls.

Shear reinforcement with T-headed bars can be calculated with the common methods given in design standards. The result will be conservative because most design standards do not take into account the special characteristics of anchorage by T-heads. Today it is only the Canadian Code CAN/CSA-A23.3-04 "Design of Concrete Structures" which allows an increase of the factored shear stress resistance of the concrete by 50% if headed shear reinforcement is used.

Shear reinforcement - walls

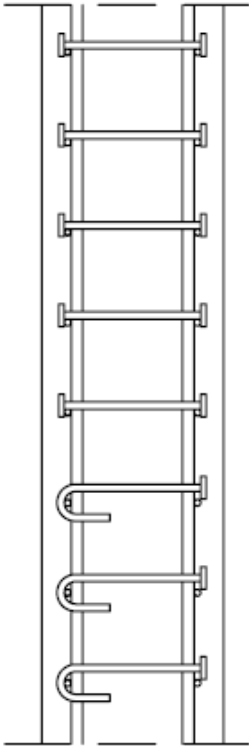

- possible with T-heads on both ends or with one T-head and one 180° hook
- secures full anchoring on both ends
- easy to install
- T-heads providing confinement effect, thus increasing the strength of the concrete

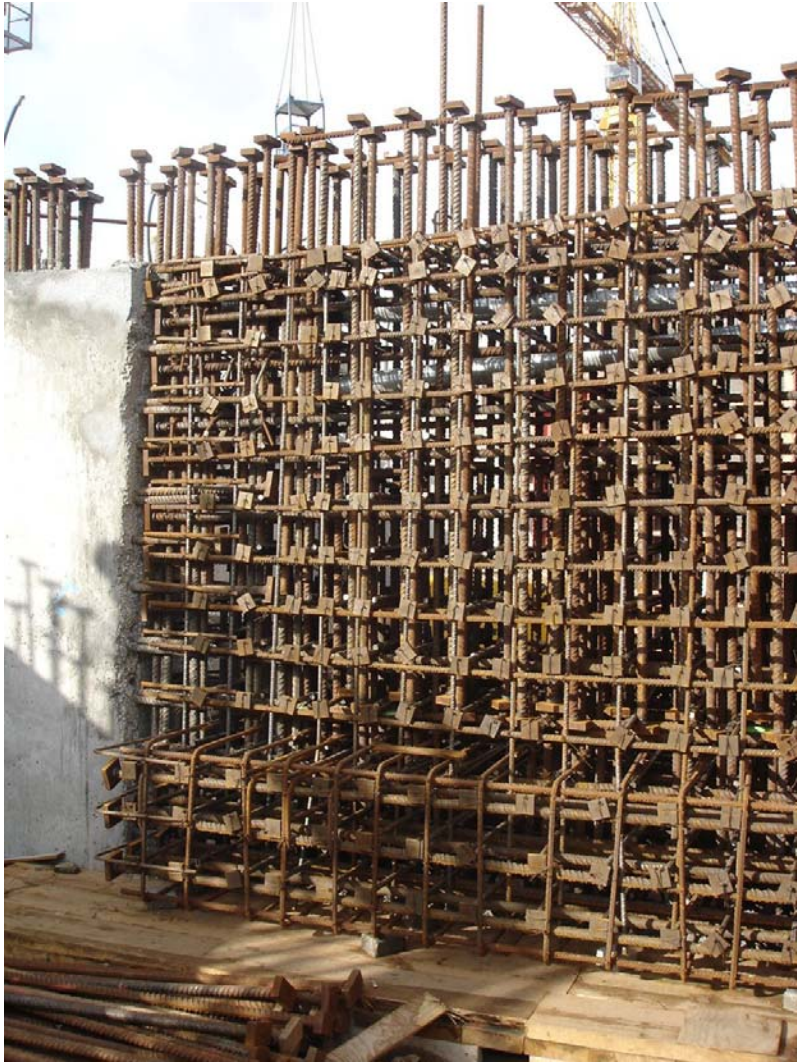

Shear reinforcement - massive slabs, foundations

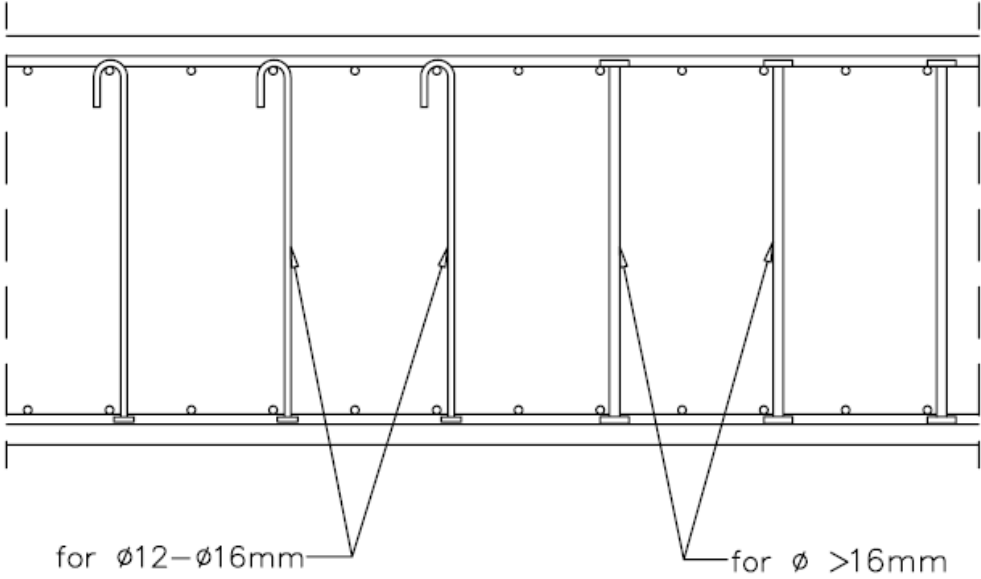

- possible to use bars with large diameter (fewer bars to place)
- secures full anchorage on both ends
- easy and fast to install
- avoids congestion



T-headed bars in Eurocode

The use of T-headed reinforcement in concrete structures is acknowledged and utilized by building designers all over the world. Many national building codes allow designers to choose the option of mechanical anchorages, such as T-headed bars.

The development of a European standard for the design of concrete structures is finished now. National standards will be replaced by the EN 1992 “Eurocode 2: Design of concrete structures” together with a national annex.

The use of T-headed bars is principally allowed by this design standard.

EN 1992-1-1:2004 states in chapter 8.4 “Anchorage of longitudinal reinforcement”:

8.4.1 (5) *“Where mechanical devices are used the test requirements should be in accordance with the relevant product standard or a European Technical Approval.”*

For reinforcing bars with large diameter the use of anchoring devices as T-heads is recommended. Chapter 8.8 “Additional rules for large diameter bars” says:

8.8 (3) *“...Such bars should be anchored with mechanical devices.”*

HRC 100 series T-headed bars have a European Technical Approval and can therefore be used when designing with EN 1992-1-1.

HRC 110, HRC 120 and HRC 150 bear the CE-marking and can as a construction product move freely within the EU & EFTA internal market.

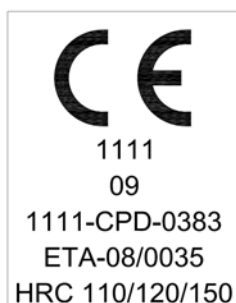

SINTEF Building and Infrastructure P.O. Box 124 Blindern N-0314 Oslo Tel. 47 22 96 55 55 Fax 47 22 69 54 38		
Authorised and notified according to Article 10 of the Council Directive 89/106/EEC of 21 December 1988 on the approximation of laws, regulations and administrative provisions of Member States relating to construction products		MEMBER OF EOTA
European Technical Approval ETA-08/0035 This ETA replaces ETA-08/0035 with validity from 31.01.2008 till 31.01.2013		
Trade name:	HRC 100 Series T-headed bars	
Holder of approval:	Metalock Industrier AS Lierstranda 107 N-3400 Lier Norway	
Generic type and use of construction product:	T-headed reinforcement steel bars	
Valid from:	08.10.2009	
Valid to:	31.01.2013	
Manufacturing plant:	Metalock Industrier AS Lierstranda 107 N-3400 Lier Norway	
This European Technical Approval contains:	7 pages including 1 Annex which forms an integral part of the document	
 European Organisation for Technical Approvals		

T-headed bars and Strut-and-Tie-modelling

The Eurocode EN 1992-1-1 allows the use of strut and tie models (see chapter 5.6.4 of the standard). Strut-and-tie modelling is a detailing and ultimate strength calculation method for discontinuity regions of reinforced concrete structures, such as abrupt changes of cross-section or locations with point loads (discontinuity regions as half joints, supports, corbels etc.).

Strut-and-tie-modelling is based on the construction of a virtual truss mechanism within the outline of the member to be analyzed. The truss mechanism consists of struts that model concrete compression fields, ties that model the tensile steel reinforcement and nodes that represent areas in which tensile steel is anchored into the concrete and strut forces are transferred into the ties.

Because of the modelling of the transfer-areas as nodes, there is only limited space for the anchoring of the reinforcement. The use of T-headed reinforcement provides clearly defined nodes for the analysis, thus securing safe design.

HRC T-heads are capable to anchor the full capacity of the rebar in the head alone.

That gives the following advantages when using strut-and-tie modelling:

- Reinforcing bars are anchored in a defined point - the T-head. Thus a broad coincidence of the real structure with the model is achieved.
- It is possible to design the construction with smaller dimensions because of the space saving type of anchoring of the rebar.
- T-headed bars are easy and quick to place, speeding up construction and better the possibilities for control.
- Due to the possibility of using larger bar diameters congestion is avoided, improving the casting conditions and ensuring good quality of the finished product.

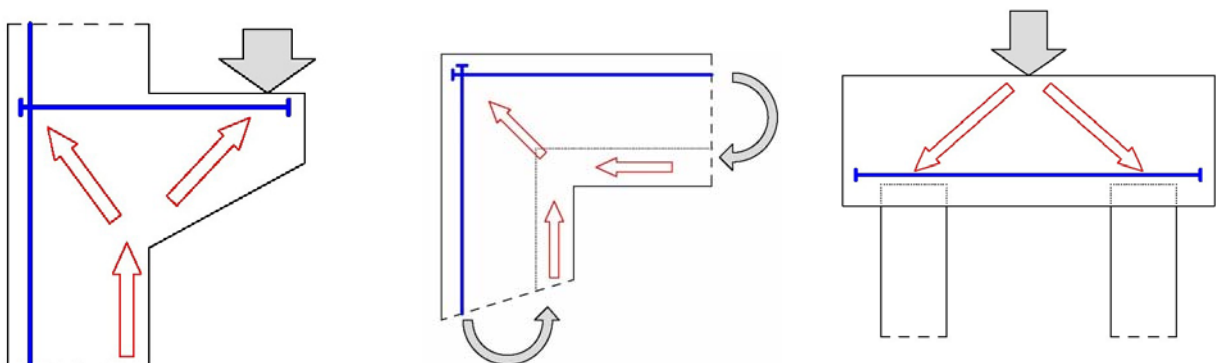

Examples: Cantilever/Corbel

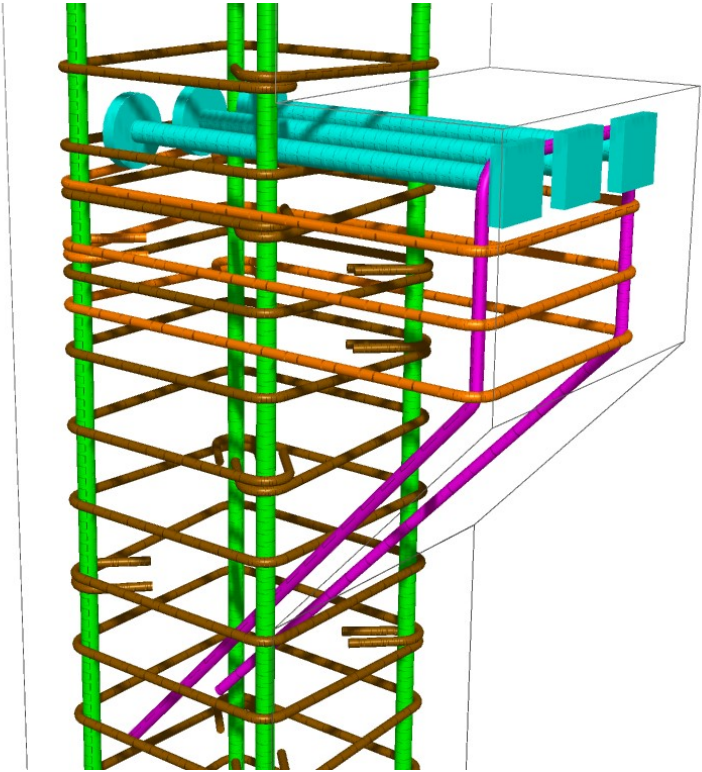

Examples: Wall-/frame corner

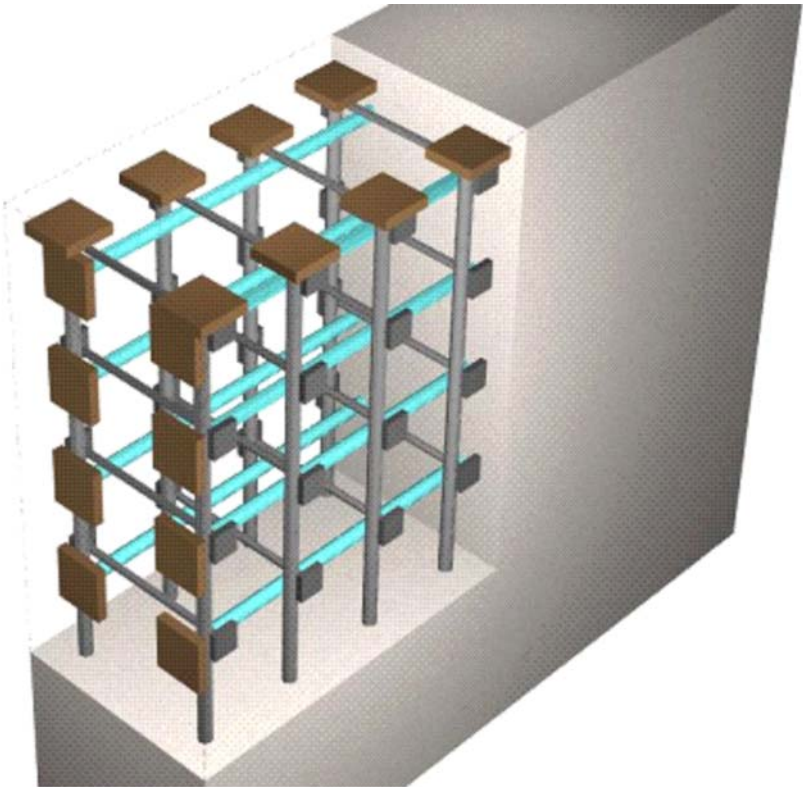

Examples: Piles and Columns

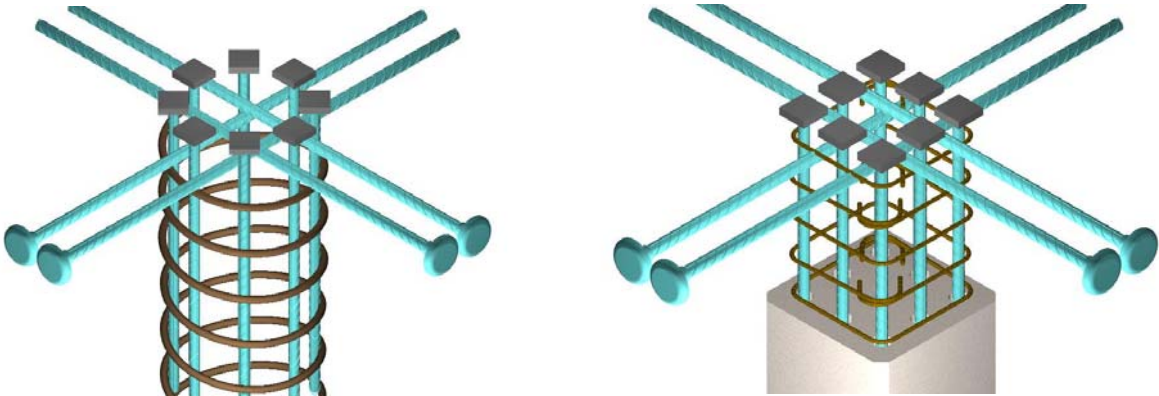

Examples: Slab with shear reinforcement

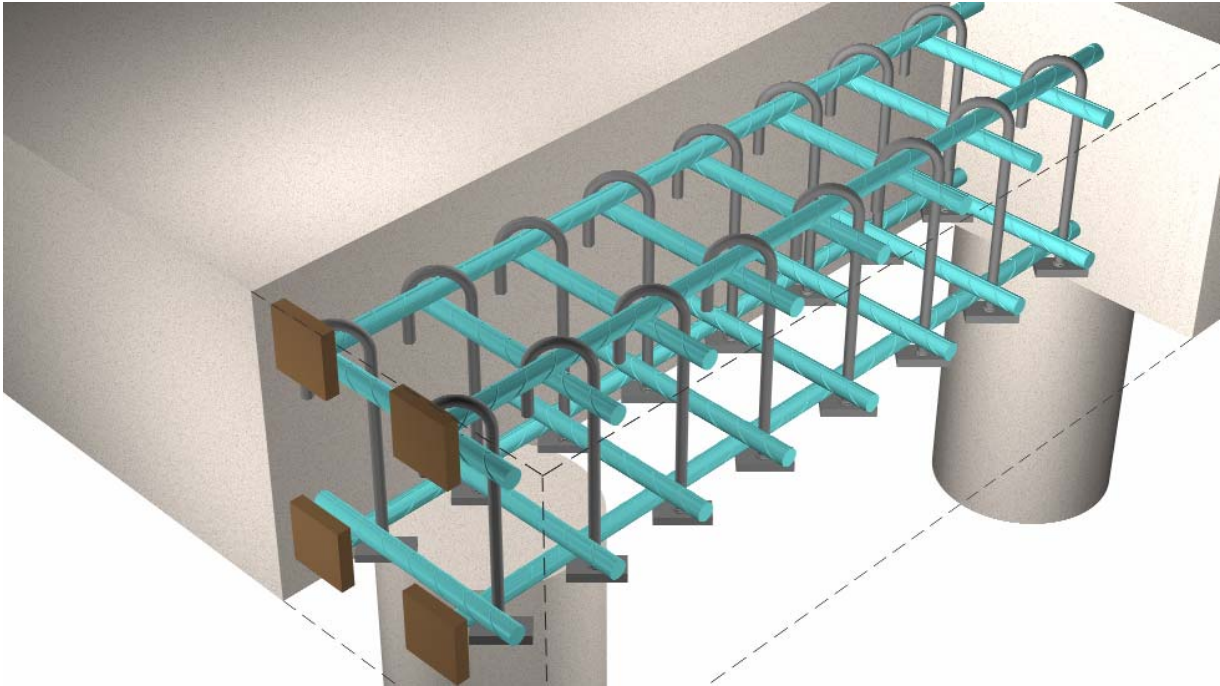

Examples: Pile caps

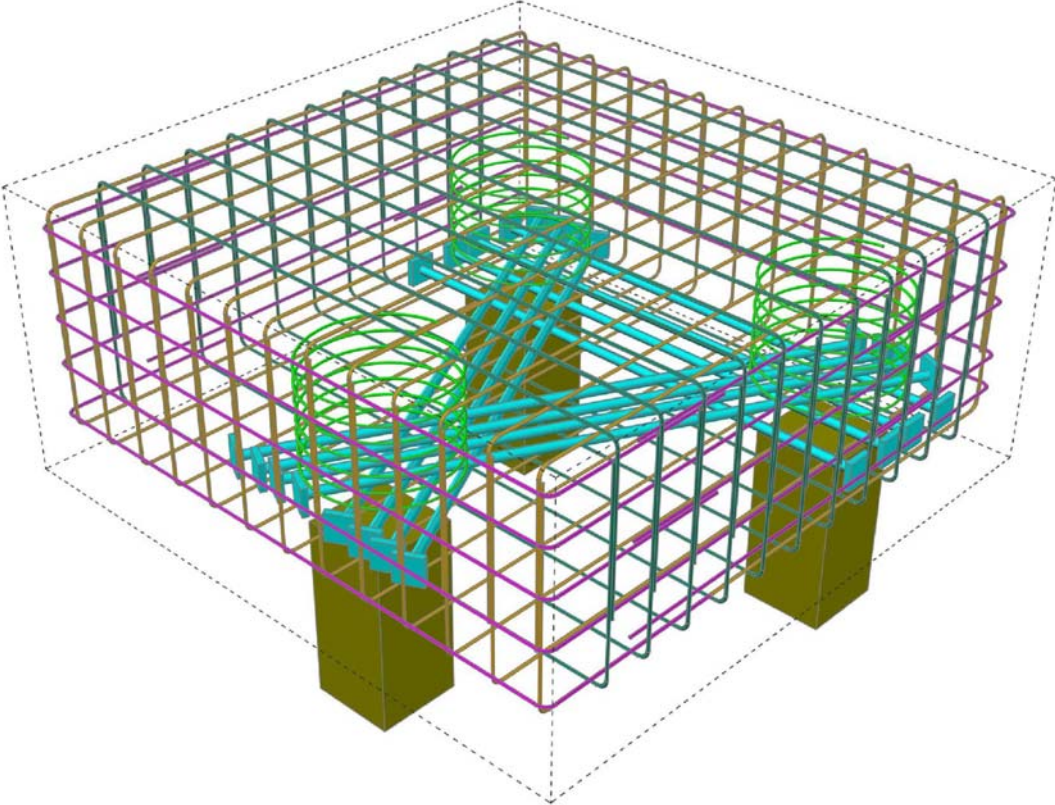
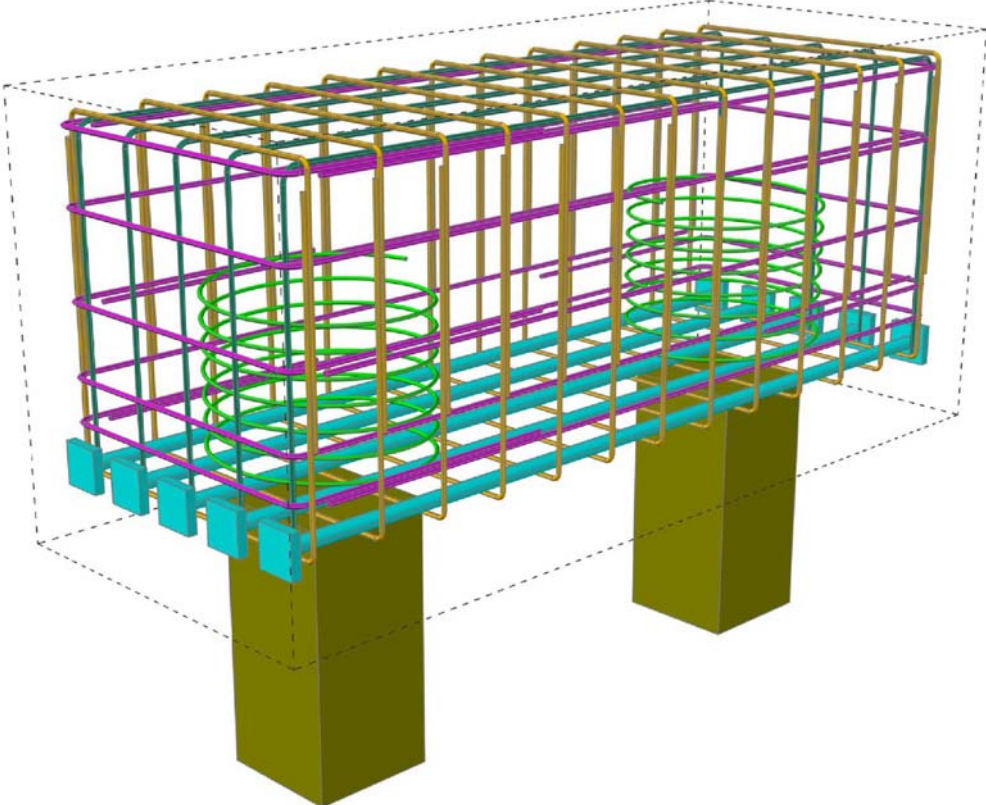

Example: Use in multi-storey buildings

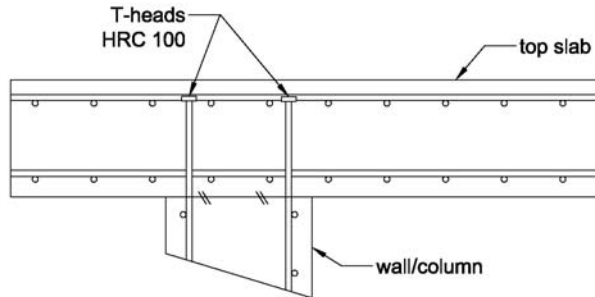

Top slab:

Anchorage of wall- or column reinforcement by T-heads avoids rebar protruding sideways, hampering the lift out of the wall-/column boarding and the placing of the formwork for the slab.

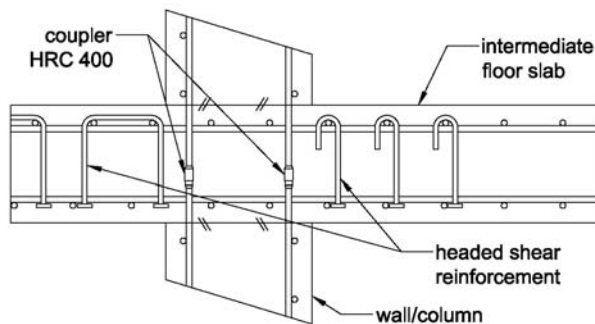

Intermediate floor slab:

Wall- or column reinforcement is spliced by HRC reinforcement couplers. The slab can be reinforced fast and efficient because there are no long protruding rebar.

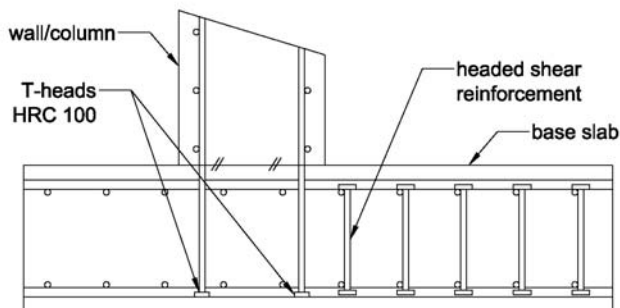

Base slab:

The reinforcement for the base slab can be placed completely before starting with the reinforcement for walls or columns. Using T-headed bars makes it possible to place starter bars into the finished reinforcement of the slab. One has flexibility because the T-heads don't need a crossing bar for anchorage (anchorage by T-head alone).

HRC T-headed bars and mechanical couplers are well suited for application together with reinforcement on rolls.

Properties of reinforcement bars

According to EN 1992-1-1:2004, table C.1

	Symbols used in		Class			Requirement or Quantile value (%)
	EN 10080	EN 1992-1-1 and EN 1992-1-2	A	B	C	
Characteristic yield strength (MPa)	R_e or $R_{p0,2}$	f_{yk} or $f_{0,2}$	400 to 600			5,0
Minimum value of ratio tensile/yield strength	R_m/R_e	$k = (f_t/f_y)_k$	$\geq 1,05$	$\geq 1,08$	$\geq 1,15$ $< 1,35$	10,0
Characteristic strain at maximum force (%)	A_{gt}	ϵ_{uk}	$\geq 2,5$	$\geq 5,0$	$\geq 7,5$	10,0

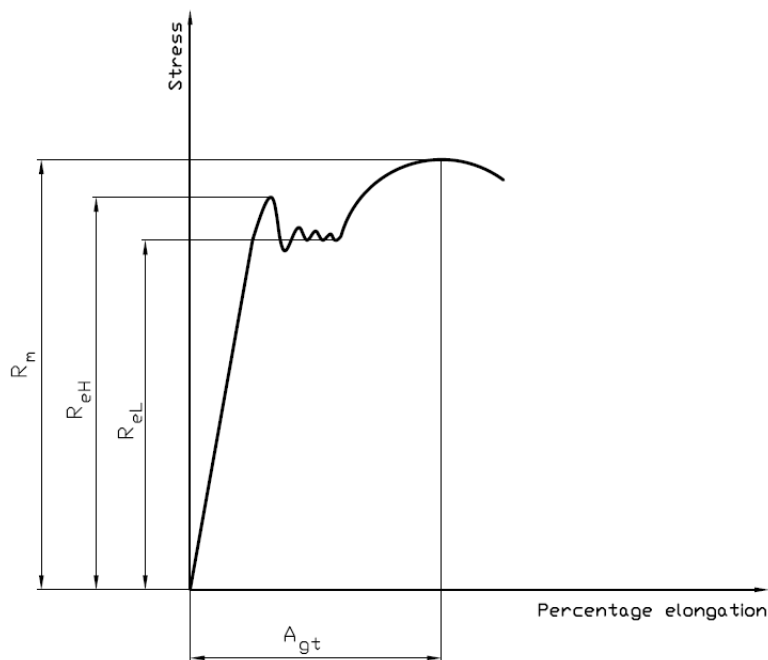

Definitions according to ISO 6892

The data and commentary provided within this document is for general information purpose only. It is provided without warranty of any kind. HRC-Metalock Industrier AS shall not be held responsible for any errors, omissions or misuse of any of the enclosed information and hereby disclaims any and all liability resulting from the ability or inability to use the information contained within.

en 4/10



HRC – Metalock Industrier AS

PO box 591, N-3412 Lierstranda, Norway

Tel: +(47) 32 24 04 70

Fax: +(47) 32 84 00 56

info@hrc-europe.com

www.hrc-europe.com

HRC USA:

www.hrc-usa.com